

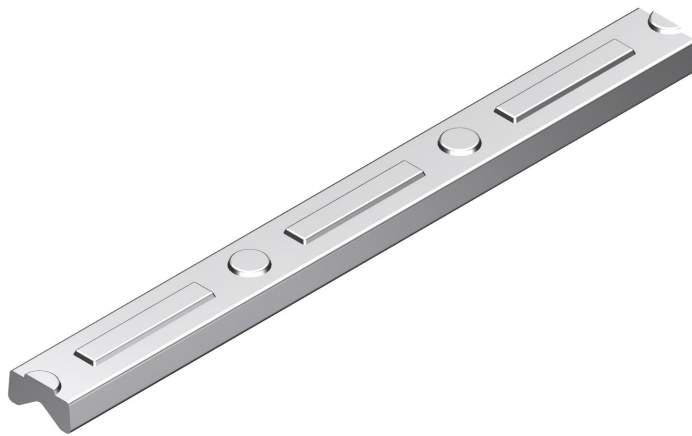

10:1



△0.3				Description: 横点花纹		 <b>金艾科</b> JINAIKE
△0.2				Size: 2.0×1.0		
△0.1				Material: SUS	Hardness: HV1 440	
Rev.	Revision description	Designed by	Date	Drawing No.:		JAK0566
Designed by:	Date:	Approved by:	Date:	Revision:	Unit of length:	
Wenjun Kang	22/07/2024	Lei Gu	22/07/2024	T0	mm	

Tolerance for linear dimensions extract from IOS 2768-1			Tolerance for angular dimensions extract from IOS 2768-1			Permissible deviations for lengths in millimeters of shorter side of the angle concerned	
Designation	from 0.5 up to 6	from 6 up to 30	from 30 up to 120	Designation	up to 10		from 10 up to 50
fine	±0.05	±0.1	±0.15	fine	±1°	±0°30'	±0°20'

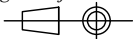
This drawing is exclusive ownership of JINAIKE.No part of this drawing may be reproduced or published, without written permission of JINAIKE