

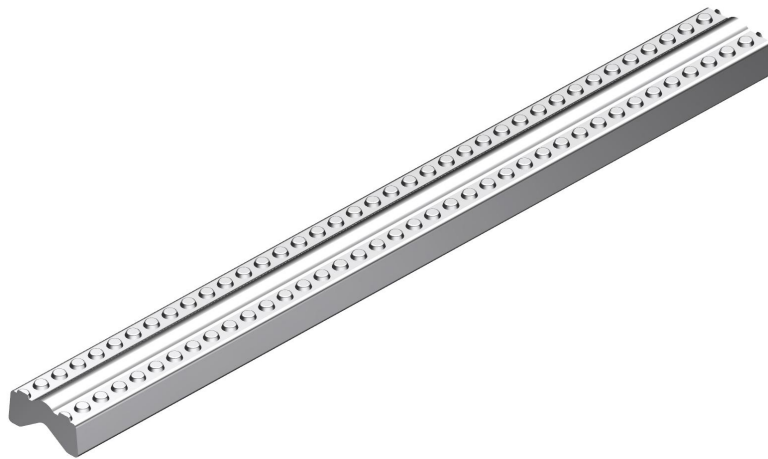

10:1



<table border="1"> <tr> <td>03</td> <td></td> <td></td> <td></td> <td></td> <td></td> <td></td> <td></td> <td></td> </tr> <tr> <td>02</td> <td></td> <td></td> <td></td> <td></td> <td></td> <td></td> <td></td> </tr> <tr> <td>01</td> <td></td> <td></td> <td></td> <td></td> <td></td> <td></td> <td></td> </tr> </table>	03									02								01								Description: 5号花纹		 金艾科 JINAIKE
	03																											
	02																											
01																												
Size: 2.0×1.0																												
Material: SUS	Hardness: HV1 440	Scale: 50:1	Drawing No.:																									
Rev.	Revision description	Designed by	Date																									
Designed by: Wenjun Kang		Date: 13/05/2024		Approved by: Lei Gu		Date: 13/05/2024		Revision: T0	Unit of length: mm	1st Angle Proj.: 	JAK0514																	

Tolerance for linear dimensions extract from IOS 2768-1				Tolerance for angular dimensions extract from IOS 2768-1				Permissible deviations for lengths in millimeters of shorter side of the angle concerned
Designation	from 0.5 up to 6	from 6 up to 30	from 30 up to 120	Designation	up to 10	from 10 up to 50	from 50 up to 120	
fine	±0.05	±0.1	±0.15	fine	±1°	±0°30'	±0°20'	

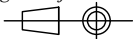
This drawing is exclusive ownership of JINAIKE. No part of this drawing may be reproduced or published, without written permission of JINAIKE